

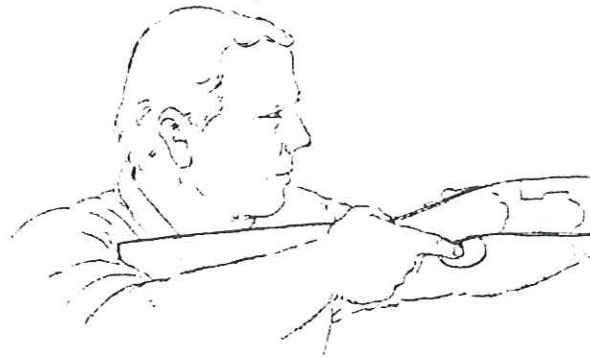

Námskeið í  
haglabyssuskotfimi  
Ýmsar myndir til leiðbeininga.

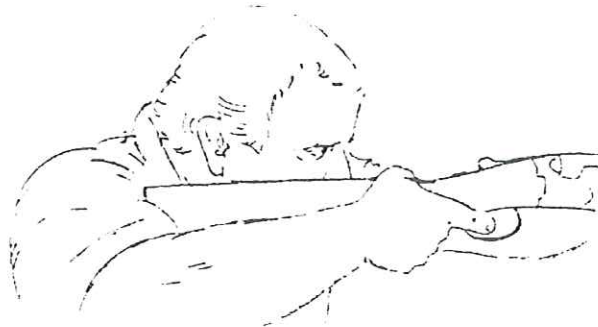

26

Rangt

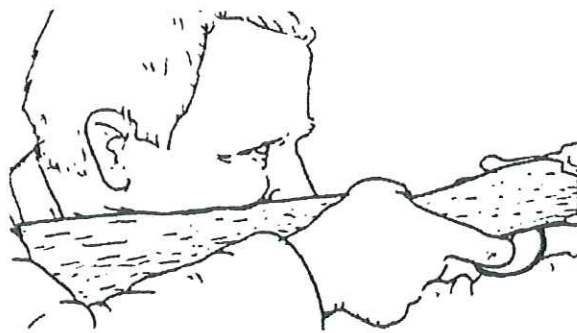

Rétt



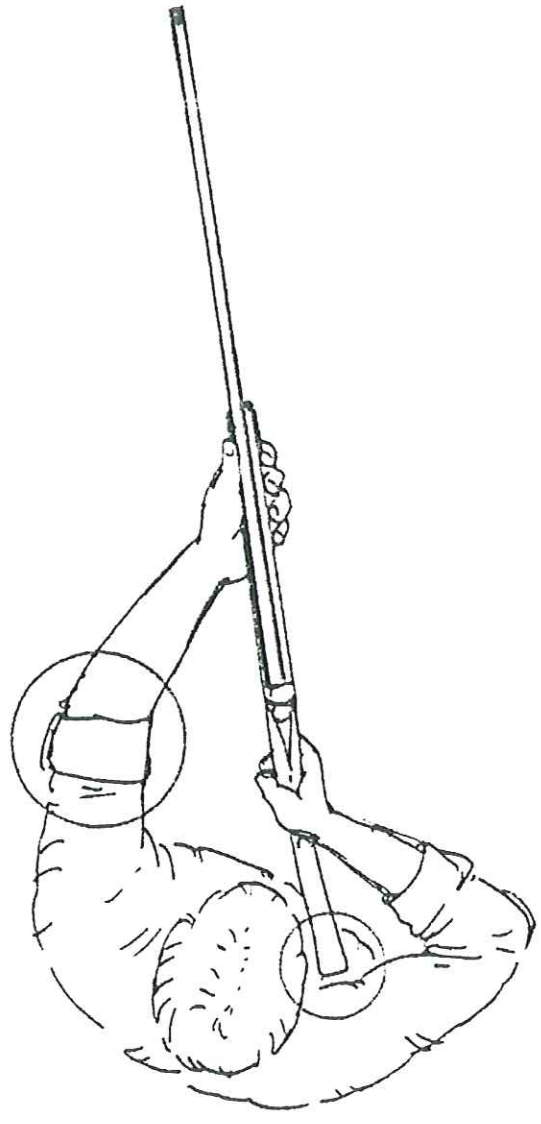

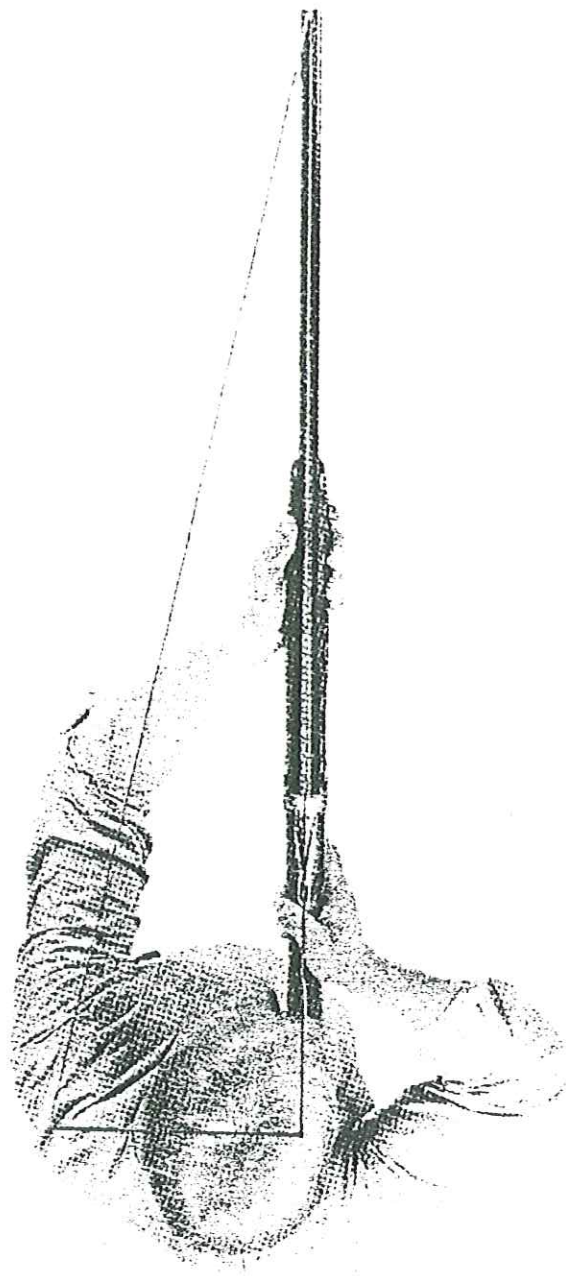

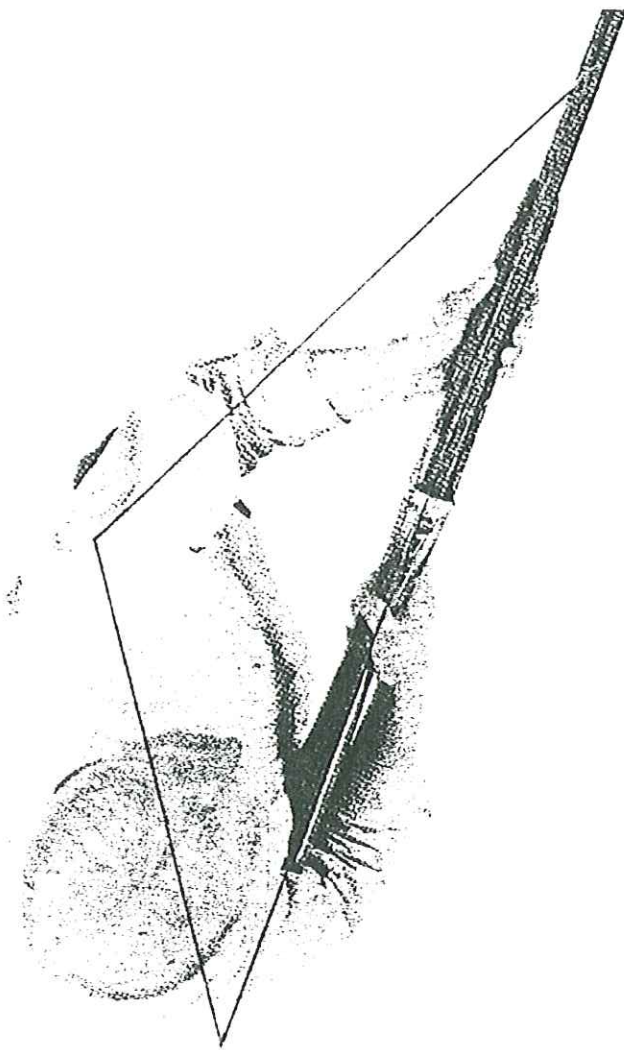

RANGT

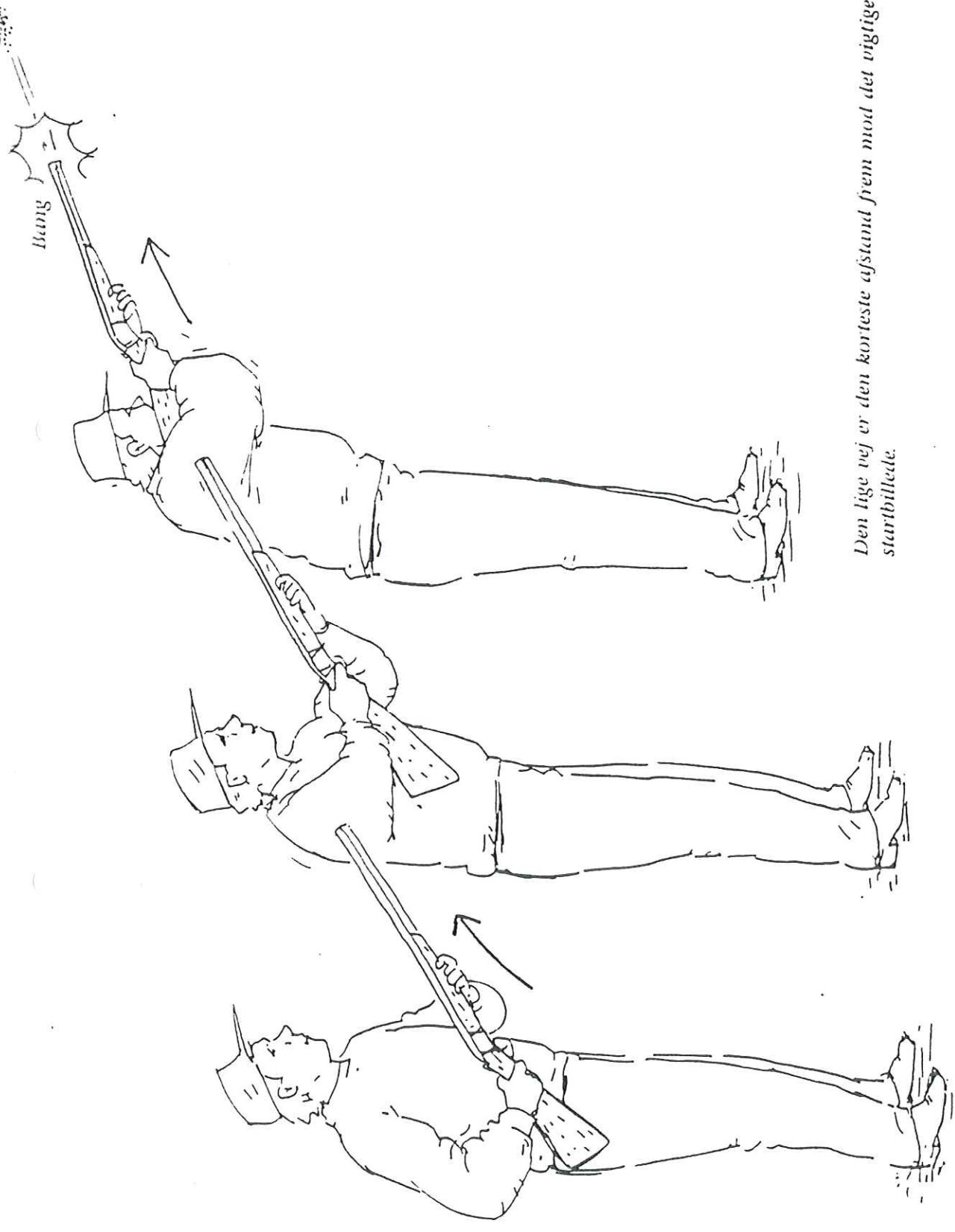

Den lige vej er den korteste afstand frem mod det vigtige startbillede.

<b>Minnisatriði</b>	<b>Athugasemdir:</b>
<b>Fótastaða</b>	
<b>Dreifing þyngdar á fætur</b>	
<b>Skefti í réttri staðsett</b>	
<b>Grip um afturskefti</b>	
<b>Grip um forskefti</b>	
<b>Staðsetning á hlaupi</b>	
<b>Hæð á byssuhlaupi</b>	
<b>Gikkstak</b>	
<b>Lyfting byssu</b>	
<b>Staðsetning byssu á öxl</b>	
<b>Staðsetning byssu á kynn</b>	



# Að skjóta á dúfu

<b>Minnisatriði</b>	<b>Athugasemdir:</b>
<p><b>Uppstilling</b></p> <p>Sjá minnisblað um uppstillingu</p>	
<p><b>Slökun</b></p> <p>Finna alla vöðva líkamans slaka. (pústa)</p>	
<p><b>Stefna hlaupsins</b></p> <p>Á hvaða palli er þú</p>	
<p><b>Hæð hlaupsins</b></p> <p>Er dúfa fallandi eða rísandi</p>	
<p><b>Tenging við dúfuna</b></p> <p>Aftanvið – beint á – framanvið</p>	
<p><b>Sveifla</b></p> <p>Hversu lengi ????????????????</p>	
<p><b>Bil framan við dúfu</b></p> <p>Á hvaða dúfur er verið að skjóta</p>	
<p><b>Skotaugnablik</b></p> <p>Ekki vanda sig !!!!!!!!!!!!!!!!!!!!!</p>	
<p><b>Eftirsveifla</b></p> <p>Ekki gleyma</p>	

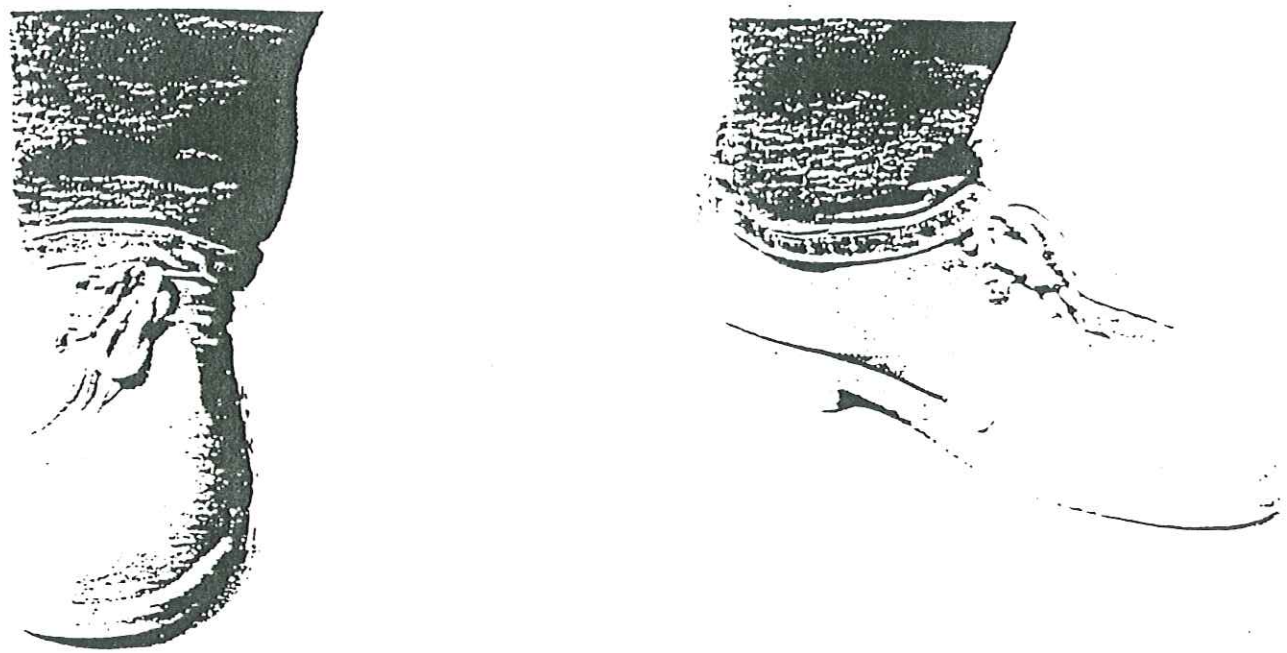

A comfortable ready stance for a right-handed shooter: feet about 10 inches apart with the toes on the leading (left) foot pointing towards the place where the clay target will be broken.



Clay gun movement and control is achieved by pivoting with the body, not the arms. The position of the feet play a crucial part in dictating smooth, accurate swing throughout the Move, Mount, Shoot sequence.

# SKEET völlum

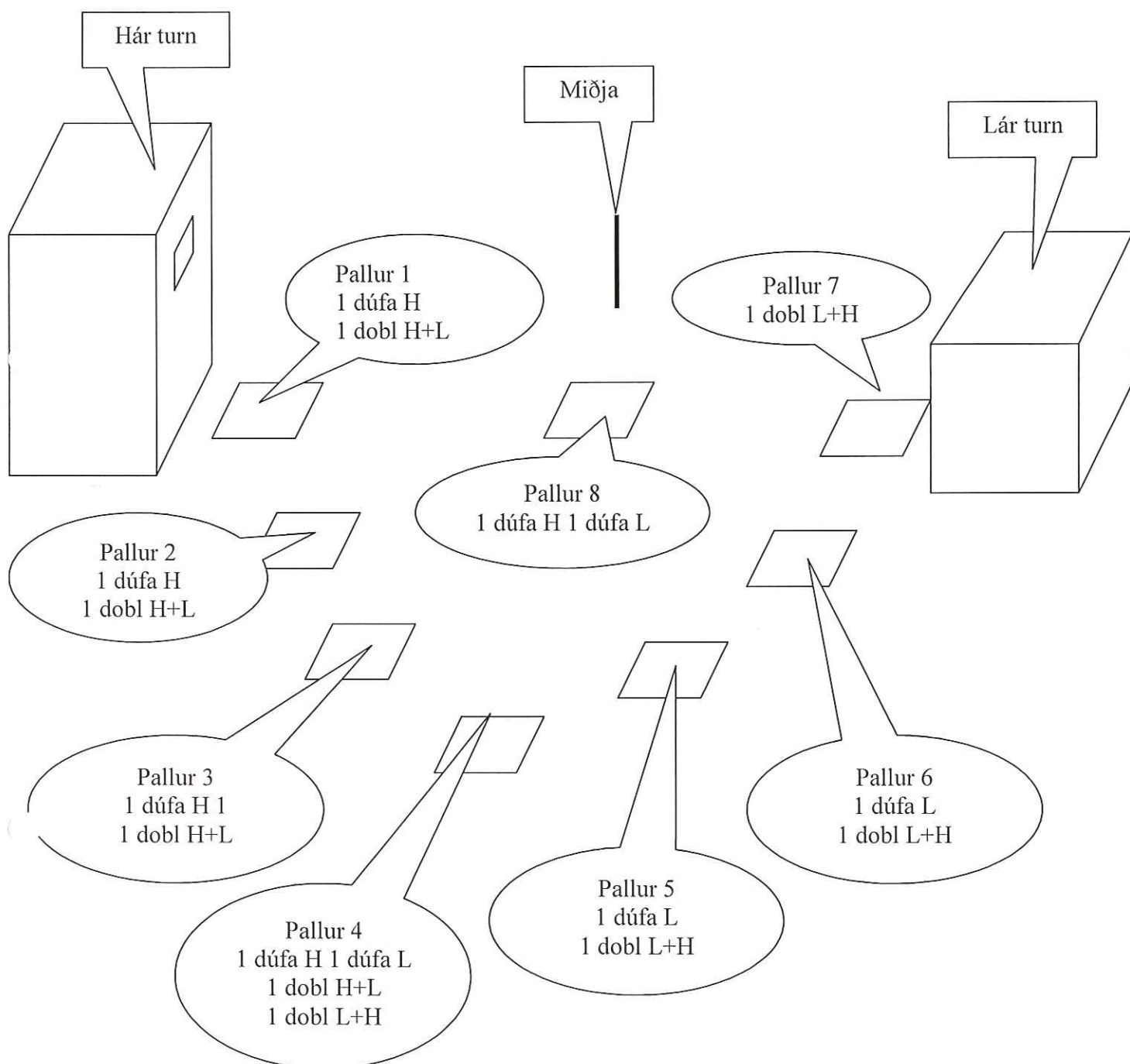

Eftir að ýtt er á takkan geta liðið allt að 3 sek. þar til dúfan kemur.

### **Hugsið um:**

Hvernig stend ég á pallinum

Hvert bendi ég byssunni

Hver er hæðin á byssunni

Er ég afslappaður í öllum kroppnum

Er ég einbeittur og tilbúinn að skjóta.

Hvar ætla ég að benda á dúfuna

Skjóta strax og þeim punkti er náð

### **Eftirsveifla**

# Nordisk trap völlum

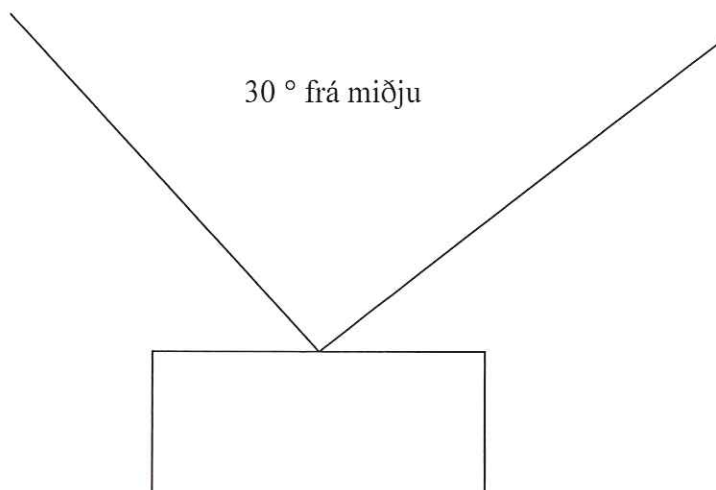

P1

P2

P3

P4

P5

Dúfan sést þegar hún er í sömu hæð og við stöndum. (eins og fugl sem tekur sig upp af jörðinni)

Dúfan getur farið í hvaða átt sem er innan við 30° vinkli frá miðju

Dúfan kemur alltaf í sömu hæð

Hver skytta skýtur einu skoti í einu, fyrst skytta á palli 1 og síðan skytta á palli 2 og svo koll af kolli þar til allar skyttur hafa skotið fimm skotum.

Þegar allar hafa skotið samtals 5 skotum færir sérhver skytta sig á næsta pall til hægri.

Ein skytta bíður og fer síðan á pall 1 í fyrstu skiptingu og skytta á palli 5 fer í bið næstu fimm skotin en fer síðan á pall 1 þegar þeim er lokið.

Eftir að ýtt er á takkann kemur dúfan strax.

Skytta á að hafa hlaðið þegar röðin kemur að henni en aðeins má hlaða einu skoti í einu

### Hugsíð um:

Stilla hlaupinu fyrir ofan mitt húsið áður en kallað er á dúfuna.

Lyfta hægt en ákveðið

Taka strax í gikkinn og kornið snertir dúfuna

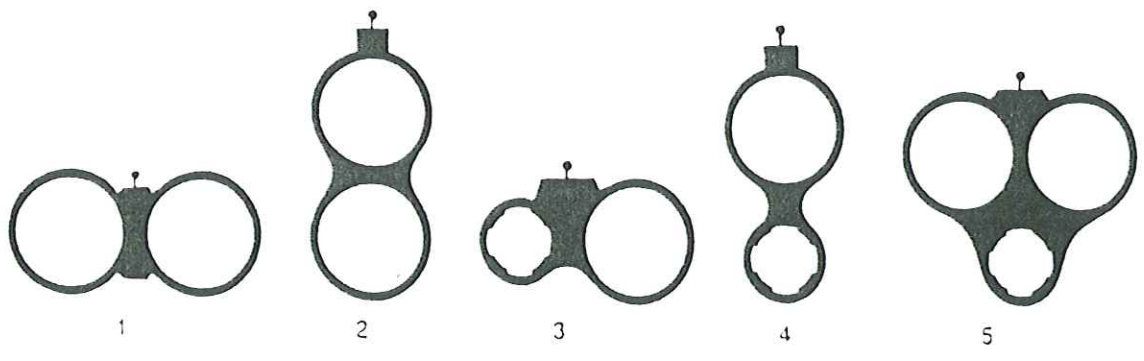

1. Sidelside. 2. Overiunder. 3. Büchsfliinte. 4. Bockbüchsfliinte. 5. Drilling.

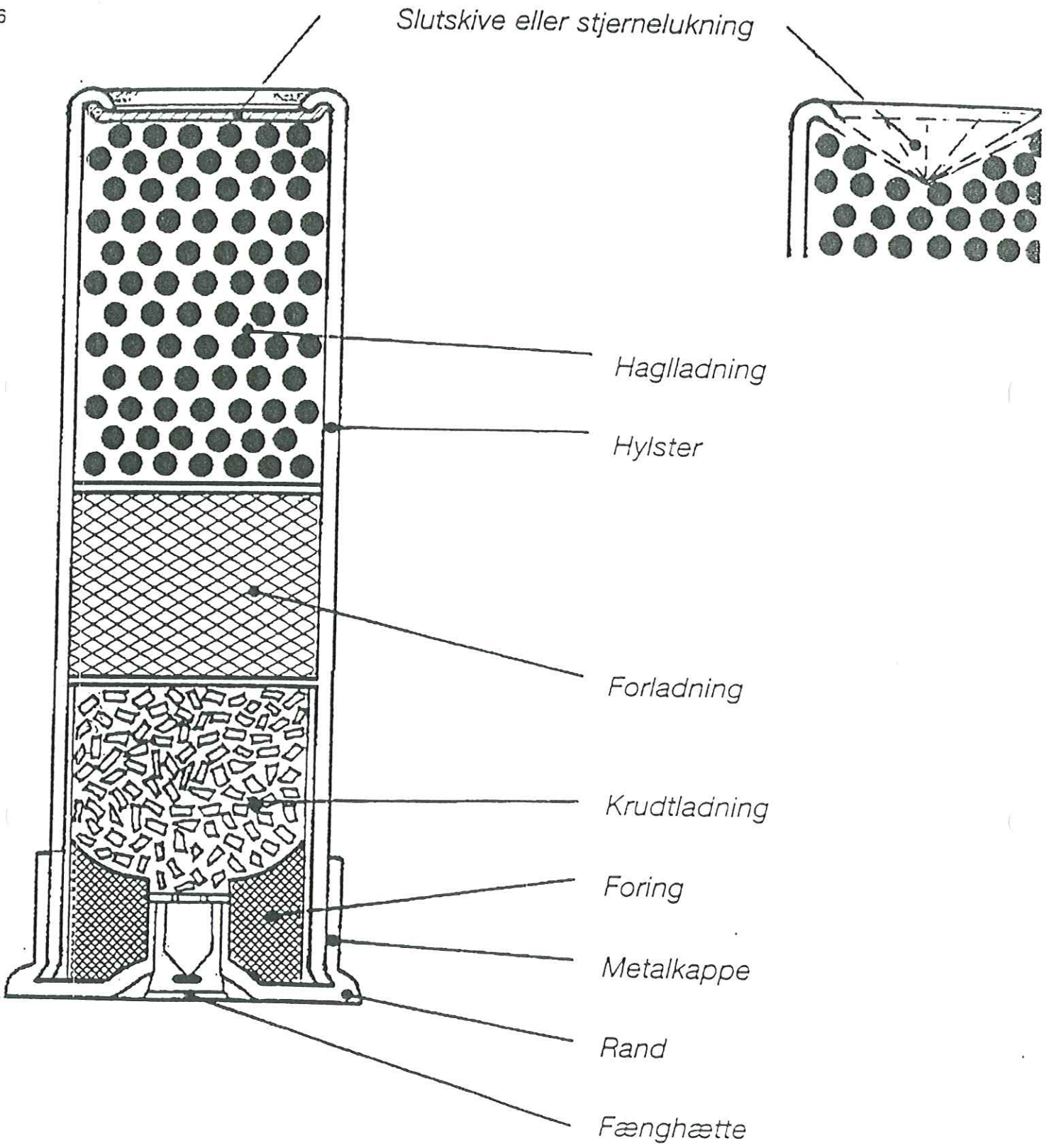

Fig. 10. Gennemskåret haglpatron.

Hagl nr. 1 =  $4,0 \times 100 = 400 \text{ m}$   
 Hagl nr. 3 =  $3,5 \times 100 = 350 \text{ m}$   
 Hagl nr. 5 =  $3,0 \times 100 = 300 \text{ m}$   
 Hagl nr. 7 =  $2,5 \times 100 = 250 \text{ m}$

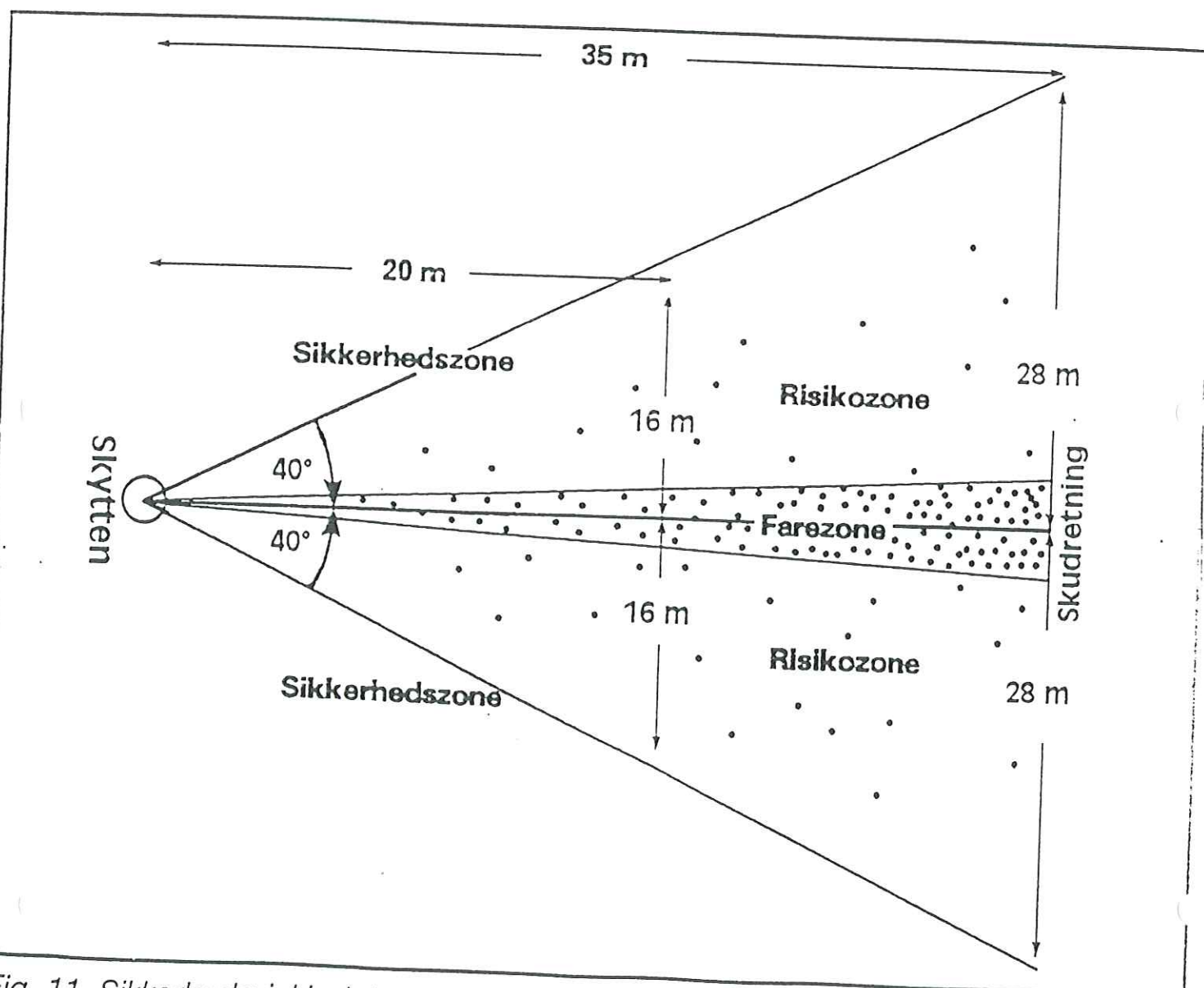
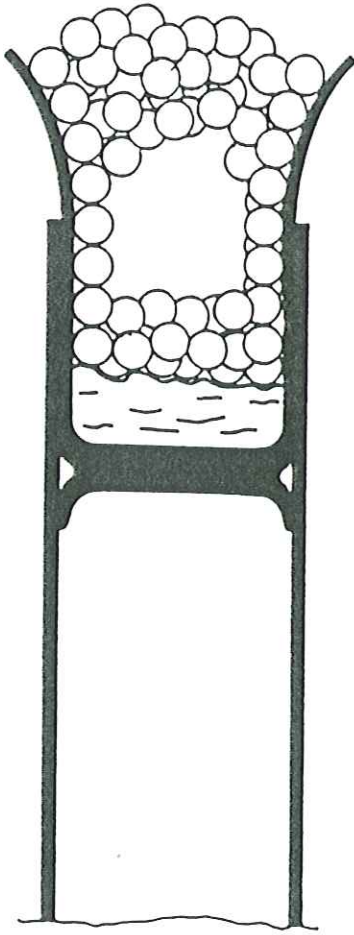

Fig. 11. Sikkerhedsvinkler/afstande.

# HAGLVBÅBNET

Cylinderboring



Skematisk tegning der viser, hvordan trangboring påvirker haglene i et åbent henholdsvis hårdt trangboret våben.

Fuld trangboring

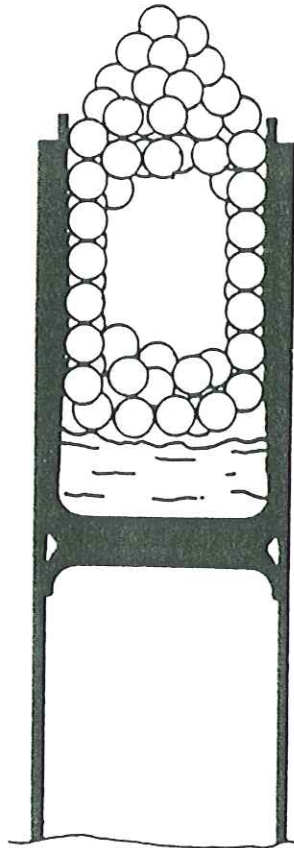

Hvad er trangboring

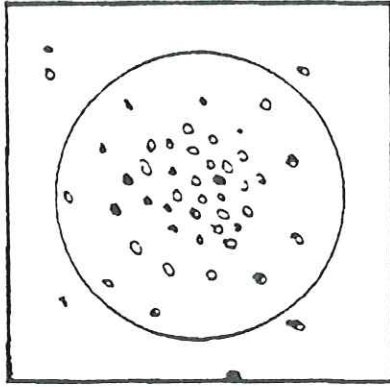

Haglfordeling fra fuldt trangboret hagløb med bløde hagl.

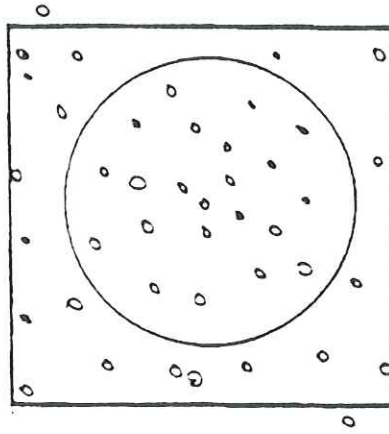

Haglfordeling fra cylinderboret hagløb med bløde hagl.

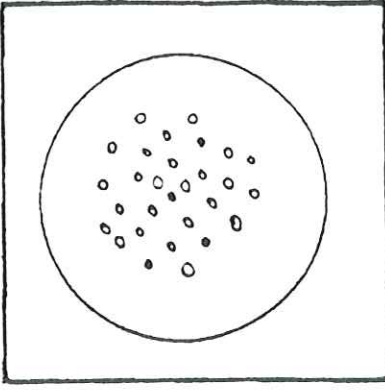

Haglfordeling fra fuldt trangboret hagløb med stålhagl.

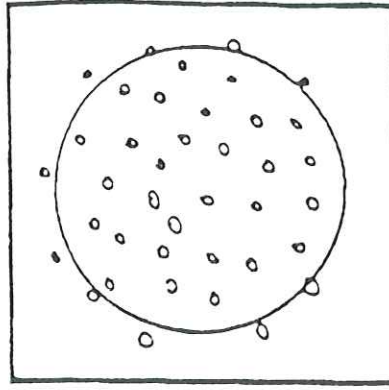

Haglfordeling fra cylinderboret hagløb med stålhagl.



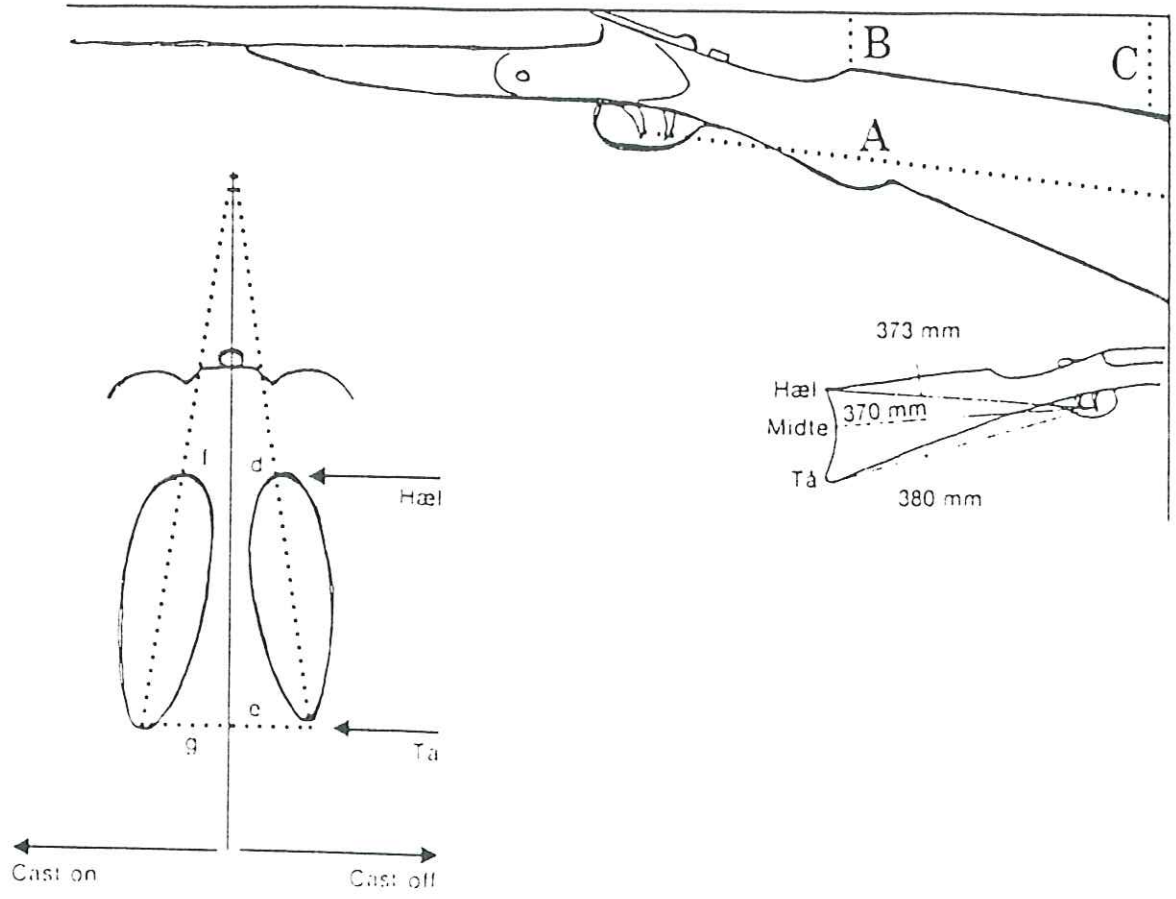

Cast on og Cast off.

Pitch down og Pitch up.

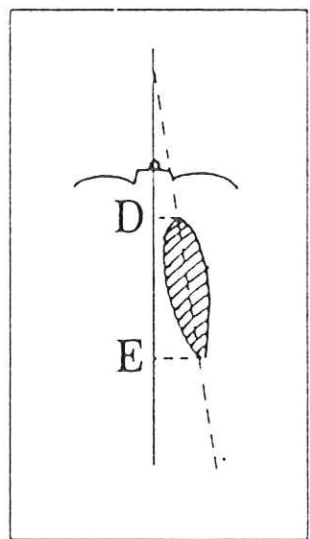

Cast off.

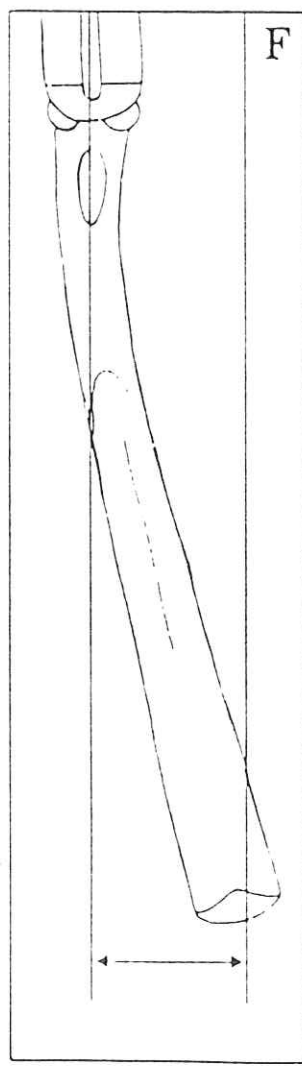

Specialbygget skæfte.

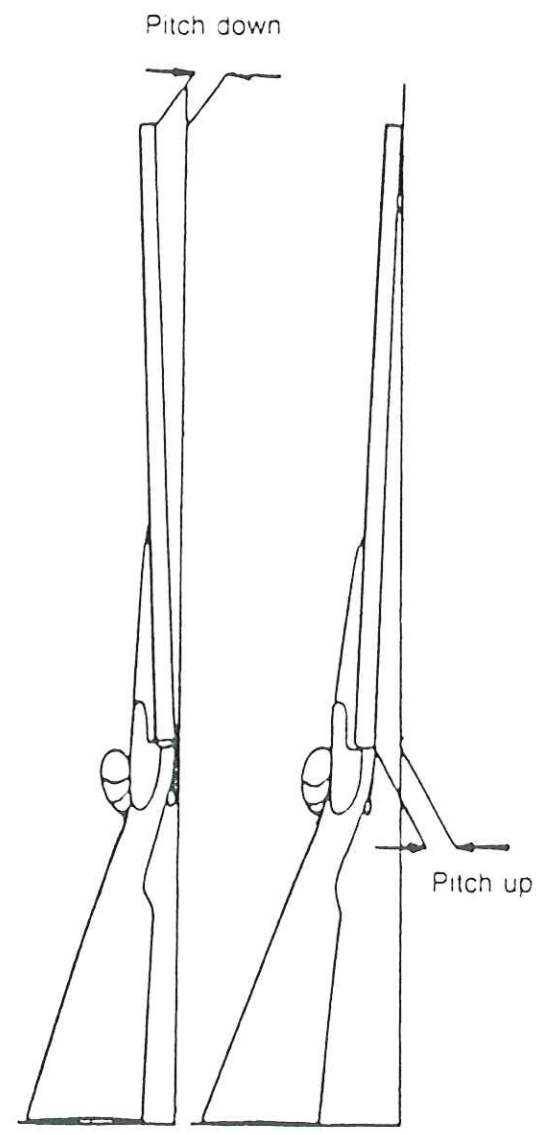

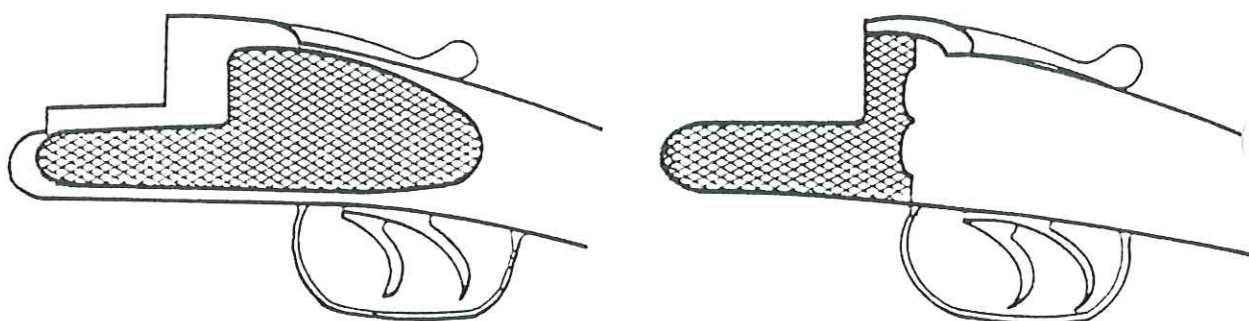

Fig. 5. Låsetyper - til venstre sidelås, til højre kasselås/boxlås.

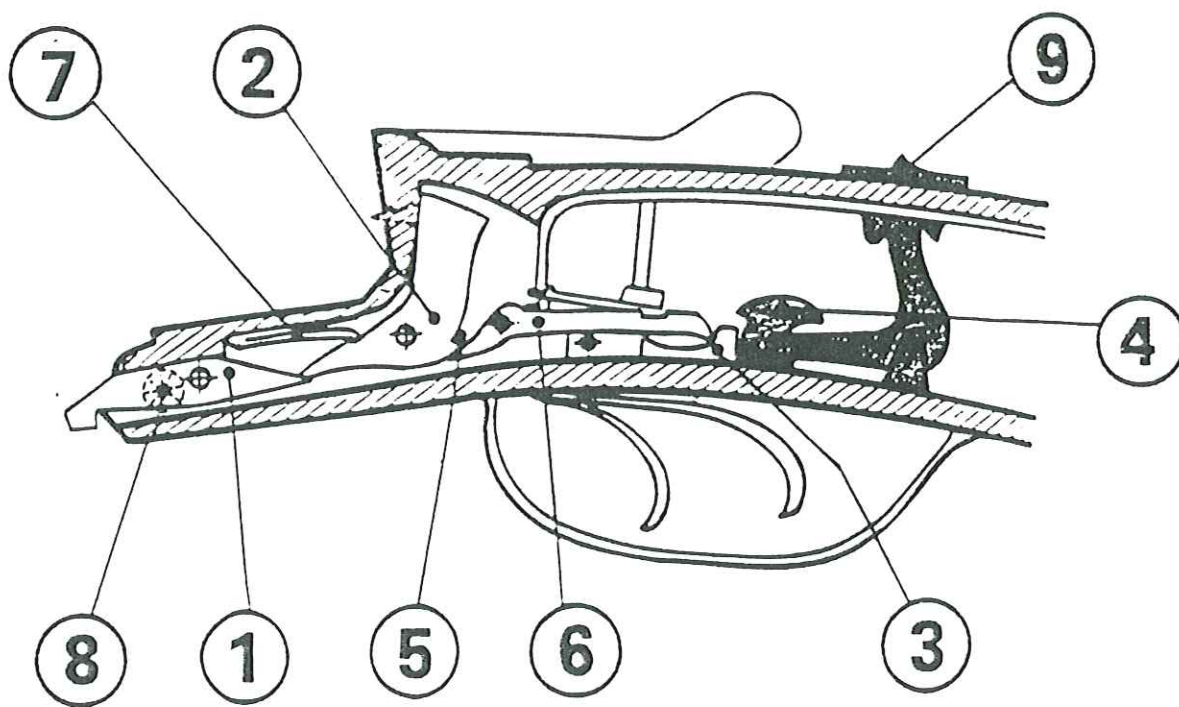

Fig. 6. Hammerlesslås. 1) Spændstang, 2) slagstykke, 3) aftrækkerblad, 4) sikringsdele, 5) spændro, 6) aftrækkerstang, 7) slagfjeder, 8) hovedbolt/tværbolt, 9) sikring, 10) slagstift.

# CHOKES

1	-	FULD	-	FULL	-	OL-Trap
2	-	$\frac{3}{4}$	-	IMPROVED MODIFIED	-	OL-Trap+Jagt
3	-	$\frac{1}{2}$	-	MODIFIED	-	Jagt+Nordisk Trap
4	-	$\frac{1}{4}$	-	IMPROVED CYLINDER	-	Skeet + Jagt
5	-	CYLINDER-	-	CYLINDER	-	Skeet